

Technical Bulletin



Bulletin No: TCH-008-041

Effective Date: 6-13-2013

Cancels: TCH-008-041 dated 6-20-2006

Page: 1 of 4

Subject: **Bendix® AD-9® Air Dryer Purge Valve Identification & Kits**

Bendix® AD-9® air dryers are available with various purge valve configurations; hard seat, soft seat and DLU discharge line unloader types. The difference between these configurations relates to the type of sealing surface for the turbo cut-off valve. This bulletin describes the three AD-9 purge valve configurations and how to identify each one. It is important to replace the purge valve assembly with the proper configuration to maintain proper air dryer operation and performance.

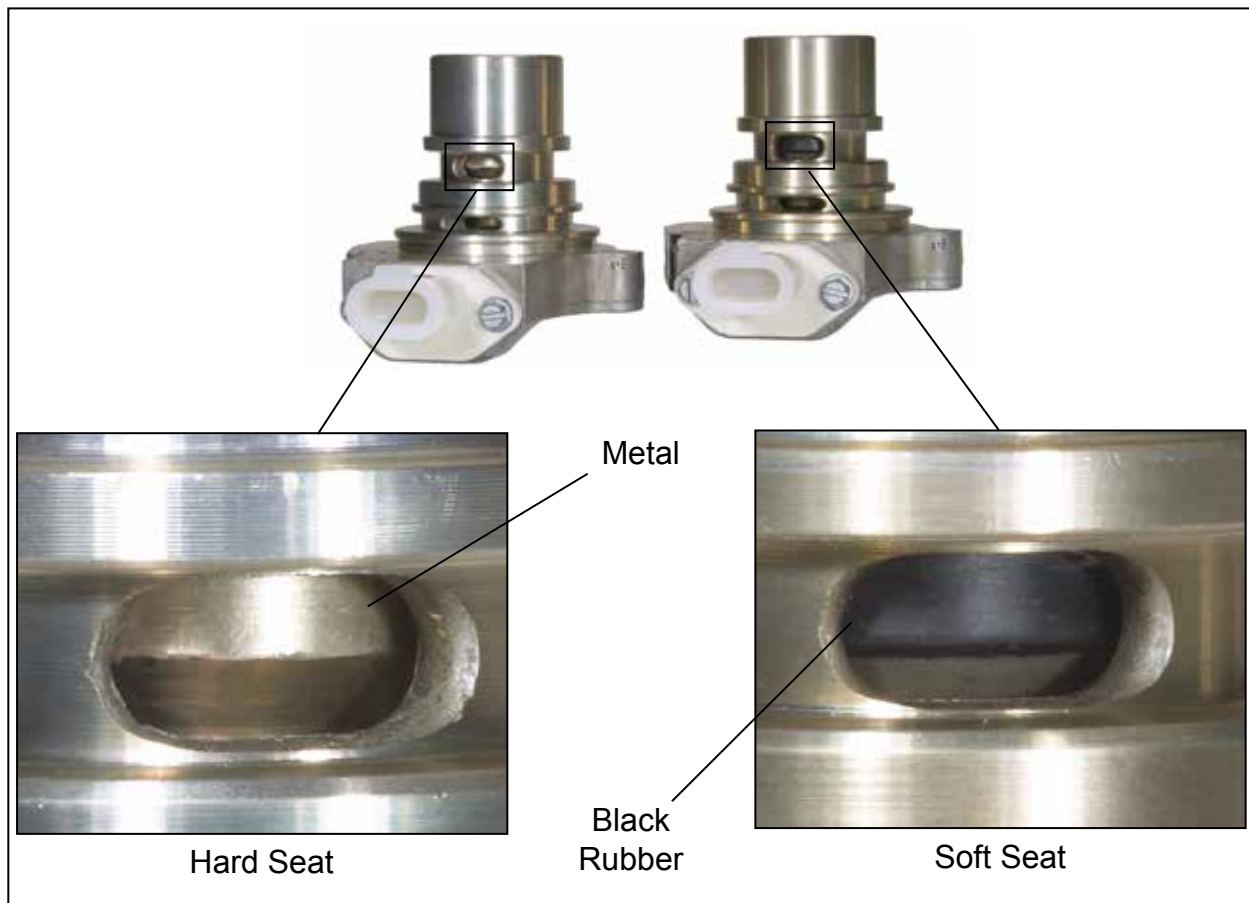

Figure 1 - Identification of Hard and Soft Seat Purge Valves

1. Hard seat purge valves have a metal-to-metal turbo cut-off valve sealing surface. Most Bendix AD-9 air dryers come standard with the hard seat purge valve.
2. Soft seat purge valves have a bonded rubber ring on the piston that contacts a metal seat on the housing to make the turbo cut-off valve seal. This seal is extremely air tight for applications that require zero leakage, such as the Bendix® EverFlow® system and drop-in style air dryers used with older Holset type E compressors.

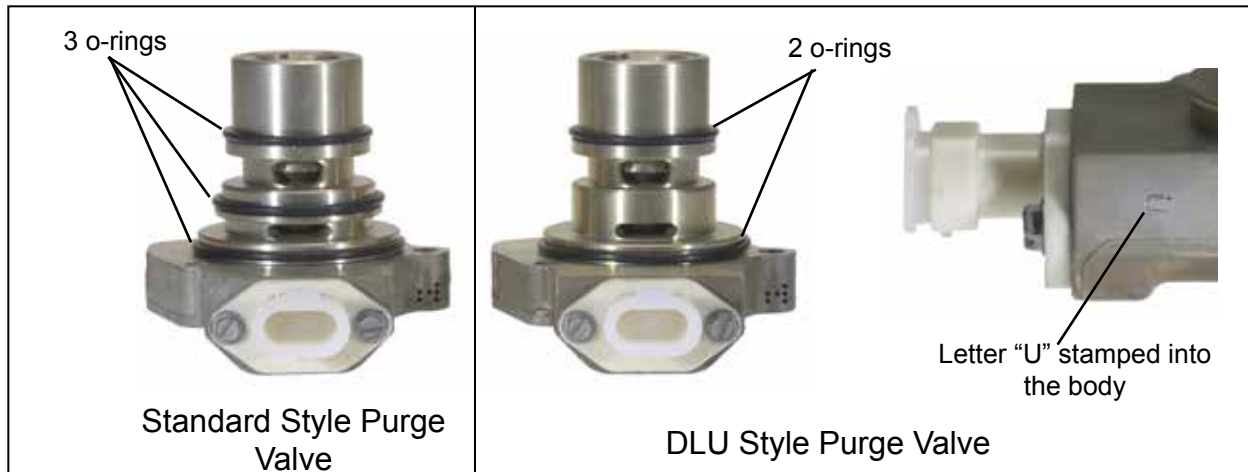

Figure 2 - Standard and DLU Purge Valves

3. Discharge line unloading (DLU) purge valves have the turbo cut-off valve bypassed. While the DLU purge valve is similar in appearance to the standard purge valve, the middle o-ring groove and o-ring sealing surface are eliminated from the housing on the DLU purge valve. This purge valve is used to positively vent the compressor discharge line of non-head unloaded compressors. See *Figure 2*.

NOTE: Although a soft seat purge valve can be substituted for a hard seat purge valve, a hard seat purge valve **must not** be substituted for a soft seat purge valve. **If the air dryer was originally equipped with a DLU-style purge valve it must be replaced with a DLU-style purge valve.**

It's important to note that with either a soft seat or hard seat purge valve, there is no effect on the air brake system pressure if moderate leakage occurs. Since the seal only isolates the compressor discharge line to the air dryer, leakage at this seal will only allow pressure bleed-down of the compressor discharge line. Therefore, any leakage differences between the hard seat and soft seat version are negligible and engine performance and driveability are maintained.

Selecting the Purge Valve Replacement Kit for a Bendix® AD-9® Air Dryer

When servicing your Bendix® AD-9® dryer with a purge valve replacement kit, you will need to identify the type of purge valve being replaced. Removal of the purge valve from the dryer body is necessary to identify the correct maintenance kit.

First, identify whether the purge valve is a DLU-style. The DLU type can easily be distinguished from the others, because the DLU type have only two o-rings on the outside of the purge valve housing, rather than the standard three o-rings. For DLU purge valves, the middle o-ring seat has been removed. Additionally, AD-9 air dryers with a DLU purge valve have the letter "U" stamped on the side of the purge valve housing. Because the letter "U" is not always visible, it is best to use the number of o-ring grooves for identification. See *figure 2*.

If the purge valve is a standard style (not a DLU), look through the upper oval hole in the purge valve housing to view the piston. If a black band encircling the piston is visible, then the purge valve is a soft seat type. If the piston is all metal, then the purge valve is a hard seat. See *Figure 1* for hard and soft seat purge valves.

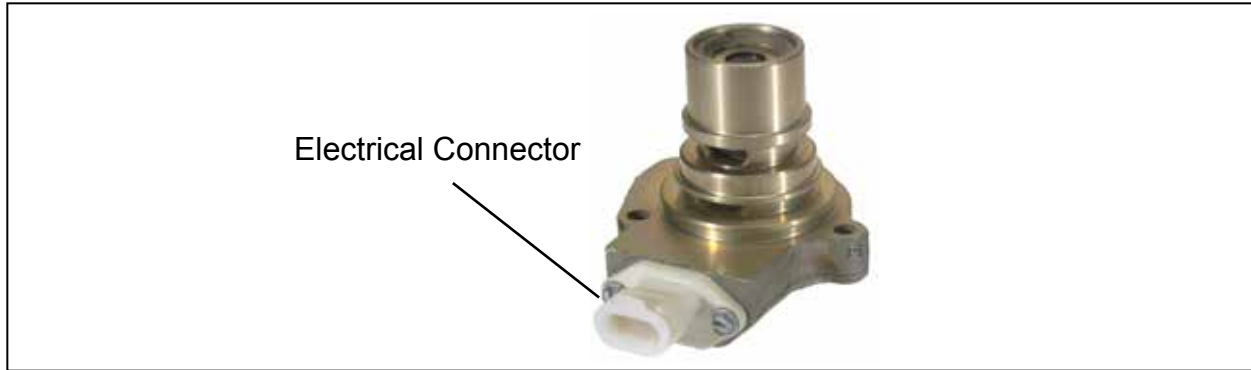

Figure 3 - Voltage and Wattage

After the purge valve type has been identified, the next step is to identify the heater size; voltage and wattage. The electrical connector on the purge valve is color coded as shown in the Purge Valve Replacement Kits table.

Once the correct maintenance kit is identified, service the purge valve following the instructions provided in the kit for proper replacement.

Bendix® AD-9® Air Dryer Purge Valve Replacement Kits

Kit Part Number	Purge Valve Type	Heater	Connector Color	Comments
5004479	Hard Seat	12V / 75W	White	-
5004480	Hard Seat	24V / 75W	Gray	-
5004381	Hard Seat	24V / 100W	Yellow	-
800405	Soft Seat	12V / 75W	White	-
5004338	Soft Seat	24V / 75W	Gray	-
5004341X	Soft Seat	12V / 75W	White	Reman.
5004342X	Soft Seat	24V / 75W	Gray	Reman.
5004339	DLU	12V / 75W	White	-
5004340	DLU	24V / 75W	Gray	-
5006580	DLU	24V / 100W	Yellow	-



Bendix® AD-9® Air Dryer Purge Valve Replacement Kits consist of these components:

Item	Description	Qty
1	Purge Valve Assembly	1
2	1/4" Cap Screw	3
3	Washer	3
4	O-ring	1
5	O-ring	1
6	O-ring (not included in DLU kits)	1
7	Lubricant	1

Log-on and Learn from the Best
 On-line training that's available when you are –24/7/365.
 Visit www.brake-school.com.