

## Section 3: The Charging System

### **3.1--An Overview of the Charging System**

The Charging system is an important part of the electrical system. It provides electrical current for the lights, the radio, the heater, the engine's electrical systems, and other electrical accessories. It also maintains the batteries in a charged state, recharging them as necessary.

In order to properly service the charging system, you need to understand how it operates. The charging system has three main components: the alternator, the voltage regulator, and the batteries.

The alternator generates electrical power to run accessories and to recharge the batteries. It is normally driven by a belt located off the crankshaft. Mechanical energy from the crankshaft is converted by the alternator into electrical energy for the batteries and accessories.

The voltage regulator acts as an electrical "traffic cop" to control alternator output. It senses when the batteries need recharging, or when the vehicle's electrical needs increase, and adjusts the alternator's output accordingly.

The batteries are a reservoir of chemical electrical power. Their primary purpose is to crank the engine. They also supply power to vehicle accessories when the electrical load is too great for the alternator alone.

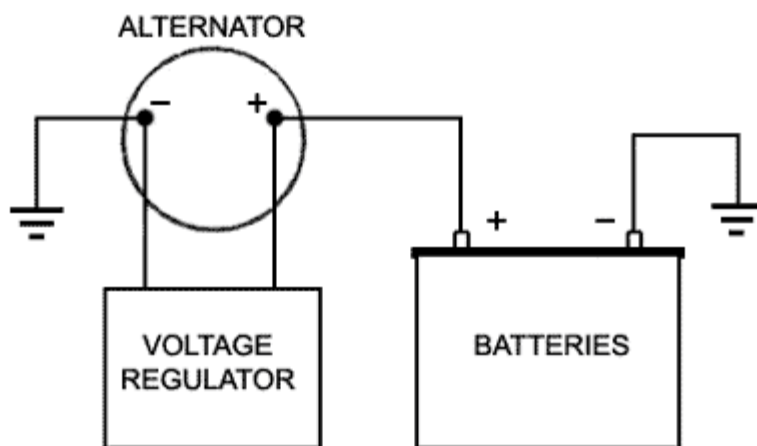

Figure 11: Wiring diagram

### **3.2--The Primary Causes of Charging System Malfunction**

Before discussing the preventive maintenance and diagnostic procedures for the charging system, we're going to cover certain environmental and product application factors that can cause the charging system to malfunction.

**Excessive heat.** An alternator can become damaged if it operates too long at excessive temperatures. Damaging heat levels are generated in two ways: when the alternator becomes dirty either externally or internally restricting its ability to dissipate heat from its external surface or not allowing air to pass through the unit, and when air ducts and heat shields are not replaced after the alternator has been serviced.

**Dirt and dust.** Charging system components operate less efficiently when buildup of dirt particles form around wire and cable connection points. Dirty connection points impair the flow of electrical current.

**Vibration.** If charging system components are poorly or loosely mounted to the vehicle's frame, the resulting vibration can damage sensitive internal components. A loosely mounted component will also diminish the performance of the important belt drives. This is very important on high powered engines.

### **3.3--Preventive Maintenance Procedures**

The object of preventive maintenance is to identify and correct the potential problems before they occur.

There are three preventive maintenance procedures that can greatly enhance the efficiency of the charging system's functions. These three procedures also represent the initial steps you should take when fully diagnosing (i.e. troubleshooting) a problem in the vehicle's charging system. The three preventive maintenance procedures are as follows:

**Clean alternator and connection points.** Insure that all alternator surfaces are clean to the point that they do not have a buildup of dirt, grease or dust. Air flow passages must also be clear so that air can easily pass through the unit. All connection points must be clean and free from corrosion.

**Component mounting brackets.** As mentioned previously, you need to make sure that the charging system components are securely mounted to their applicable brackets; the brackets, in turn, need to be bolted securely to the engine. Again, if charging system components are poorly or loosely mounted, damaging vibration and diminished belt drive performance are the result.

**Tension and condition of belts** You need to also check the belt for proper

tension. **Caution: be sure the engine is turned off.** A loose belt will slip on the pulley and fail to turn the alternator's rotor. Check belt tension with cricket belt tension gauge. Refer to vehicle manufacturer's specifications for proper belt tension. Before you adjust it, however, tilt the belt and inspect it for glazing, cracks, or dryness. A worn or damaged belt should be replaced.

If the belt is in satisfactory condition, use a belt tension gauge and check the results, see Figure 12. Different belt systems use different gauges. Use proper tensioning gauge for your application. Then adjust the tension according to the manufacturer's specifications.



Figure 12: Belt tension gauge

If you replace a worn or damaged belt, the new belt should be checked for proper tension as well. A new belt loses 60% of its tension in the first few hours of operation. So it needs to be tested under heavy load, and then retensioned. After a new belt is installed, run the engine - with every accessory turned on - for 15 minutes (this puts a heavy load on the belt). Then check the belt tension again and adjust it if needed. Please note that belts on high amperage output alternators may need retensioning twice after installation. Further note that if the vehicle has a multi belt drive, the belts need to be matched. Finally, in most cases and on most vehicles, belt tension should be tested every 10,000 miles.

### **3.4--Diagnostic / Troubleshooting Procedures**

Timely preventive maintenance of the charging system should keep it running smoothly. However, when a problem does occur, effective diagnostic (i.e. troubleshooting) procedures will help you locate and correct the problem quickly and economically. **In performing any diagnostic procedure, refer to the safety information section in the Introduction**

## section 1.6.

Any discussion about the electrical system must begin with the batteries. Before you begin analyzing the charging system, you must be sure the batteries have been properly tested and are at least 75% charged. Otherwise, any electrical tests you conduct on the charging system will be inaccurate. (Please refer to Section Two of this manual for procedures on testing and charging batteries).

We're now going to show you how to perform four different tests specifically related to the charging system.

**Alternator Performance Test.** Connect voltmeter to alternator terminals and ammeter to alternator's positive output cable, per Figure 13. Make sure ammeter is at least 6 inches (15 cm) away from alternator to eliminate the possibility of faulty readings. Make sure voltage is present at alternator's output terminals. Start engine and run it at 1500 RPM's (operating RPM). Check that all vehicle loads are turned off and reading on ammeter is less than 20 amps. If ammeter reading is greater than 20 amps double check that all vehicle loads are turned off and that batteries are fully charged. Record voltage on voltmeter. Reading should be between 13.8 & 14.4 v for a 12 volt system, 27.8 & 28.4 v for 24 volt systems. If the voltage is not within these ranges then try adjusting the regulator if available. If the regulator can not be adjusted alternator is defective.

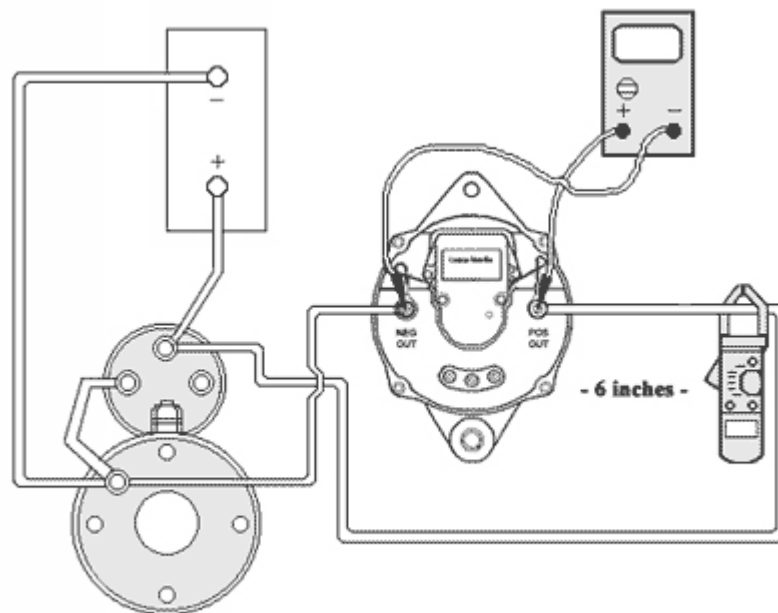

Figure 13: Alternator performance test under load

**Alternator Performance Test Under Load.** Keep engine running at 1500 RPM (operating RPM) and meters are connected per Figure 13. Turn on vehicle loads until 75% of the

alternator's rated output is achieved on ammeter display. Record voltage on voltmeter. Compare reading to that taking during the Alternator Performance Test. If alternator voltage drops more than .5 volts for a 12 V system and .7 volts for a 24 V system then alternator is defective. An alternative method of putting load on an alternator is with a carbon pile tester. Connect carbon pile tester across batteries. Adjust carbon pile until desired reading is obtained on ammeter. Record voltage on voltmeter and shut off vehicle.

**Alternator Cable Test.** To test the positive cable connect the ammeter to the positive cable from the alternator. Make sure the ammeter is at least 6 inches (15 cm) away from the alternator to eliminate the possibility of faulty readings. Connect the voltmeter's negative lead to the positive terminal of the alternator and the positive lead to the positive terminal on the battery, see Figure 14. Start engine and set engine RPM to 1500 RPMs (operating speed). Turn on vehicle loads until 75% of alternator's rated output is achieved on ammeter display. If necessary use a carbon pile tester to apply load on alternator. Record voltage on voltmeter. If reading is greater than .25 volts in a 12 volt circuit or .50 volts in a 24 volt circuit check all wire connections and cable connections. If reading is less than .25 volts in 12 volt circuit and .50 volts in a 24 volt circuit cables are good. Turn off vehicle loads and shut off engine. To test the negative cable move voltmeter's negative lead to the negative terminal of the battery and the positive lead to the negative terminal of the alternator, see Figure 15. Run test again. Use Figure 16 for recommended wire sizes for any cable repairs.

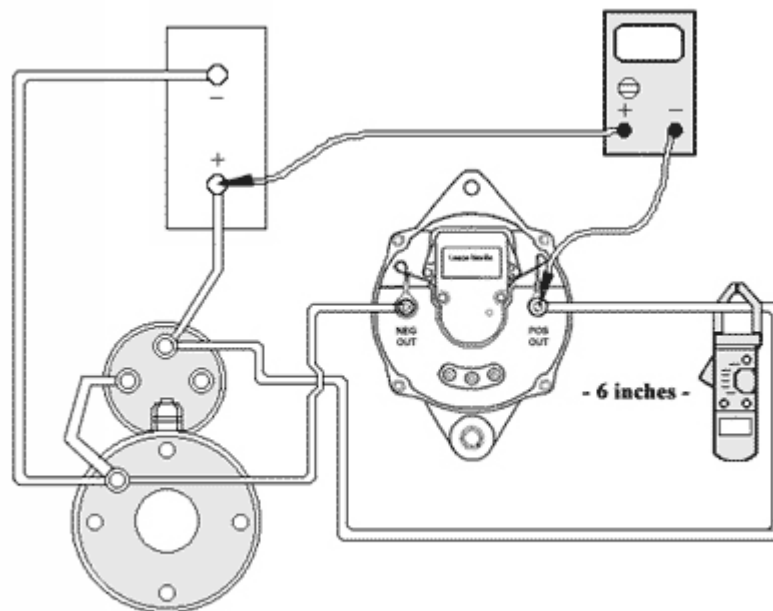

Figure 14: Positive cable test

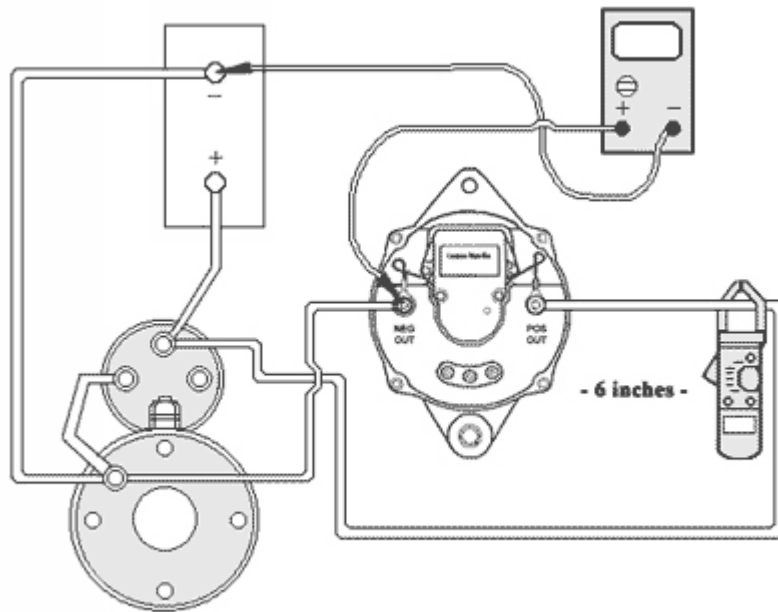

Figure 15: Negative cable test

### **3.5--Alternator Replacement**

In the event that all of the diagnostic / troubleshooting procedures point to a faulty alternator, you'll need to select a new alternator. Its "amperage capacity" rating must support the vehicle's intended application, or load and duty cycle.

If the vehicle has had a history of charging problems and you've eliminated failure in the system, you may want to reevaluate the capacity of the alternator.

When installing a new alternator and retensioning belts, be sure to carefully follow the instructions noted earlier in this section under "preventive maintenance".

See Appendix A, B, and C at the end of this manual for the Alternator Sizing Worksheet, Trouble Shooting Flowchart, and Alternator Test Procedure Flowchart.