

## Table of Contents

<b>Sheppard Power Steering M100PDP1</b> .....	3
<i><b>Steering Gear Identification</b></i> .....	3
<i><b>Preventative Maintenance</b></i> .....	3
<i><b>Power Steering Noise / Service Bulletin</b></i> .....	4
<i><b>Removal / Replacement</b></i> .....	4
Video of the steps and tools required to remove and install the steering box in a U320 .....	5



# Sheppard Power Steering M100PDP1

The M100PDP1, used in 2003 & other years is made specifically for Foretravel and can only be purchased from them. Replacement seal kits are available from <https://www.rhsheppard.com/>

Its been reported that replacement with a [M100PGW1](#) works well. You can also choose to have the unit rebuilt, one vendor that is often mentioned is [Read Head Steering](#), expect to pay at least \$900.

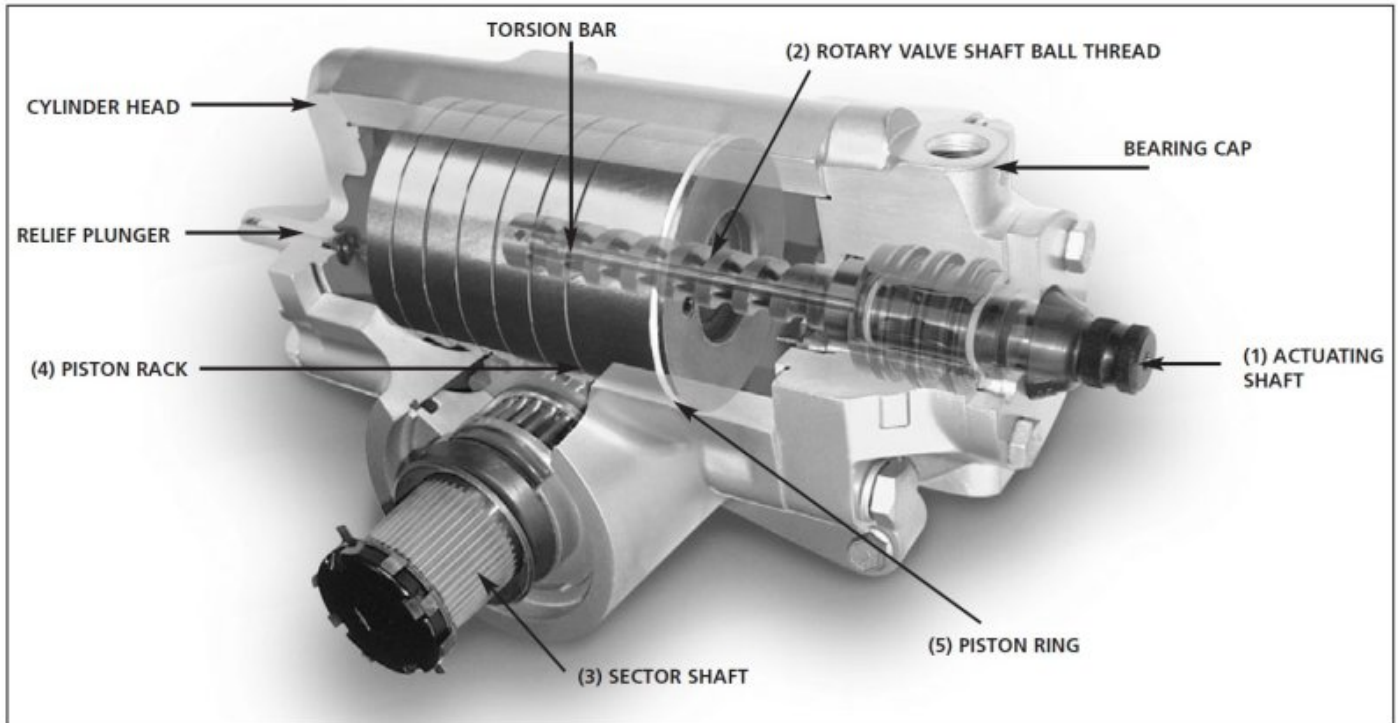

Follow the Vehicle manufacturer's recommendation for how often the steering system fluid and filter should be changed. At a minimum, this maintenance should be performed every year or every 100,000 miles, whichever comes first.

[M-Series Power Steering Service Manual](#)

## Steering Gear Identification

[Steering Gear Identification](#)

## Preventative Maintenance

Power steering fluid and filter change is necessary to keep the system clean. The use of high quality fluids and filters will insure removal of contaminants and dissipate heat. The recommended interval for power steering fluid and filter change is once a year.

Preventive Maintenance should be completed as follows:

- All fluid should be drained from the power steering system.
- The steering should be slowly cycled stop to stop to push all remaining fluid out of the steering gear.
- The filter should be removed from the reservoir and the reservoir thoroughly wiped clean with lint-free rags to remove all the particles too small for the filter to catch.
- A new filter installed in the reservoir.
- The system filled with new fluid per the truck manufacturer's specification.
- Bleed any air from the system, check for leaks, and return vehicle to service.

### maintenance Checks

## Power Steering Noise / Service Bulletin

It is possible to hear an audible hiss at the steering wheel during a steering maneuver.

This noise can be considered normal and does not adversely affect steering performance. Hydraulic fluid operating under high pressure in a steering system can occasionally create a turbulence as the fluid passes through the flow orifices of the control valve of the steering gear generating an audible sound in the driver compartment. On occasion the resonant frequencies of the chassis and steering gear intersect resulting in this audible hissing sound being transmitted through the steering column. Steering output and performance are not compromised as a result of this noise and operation of the steering system will not be affected. In most cases where a noise is present in the steering system, the noise is prevalent only at static steer or low speed maneuver.

Steering noise is not an operational or warrant-able repair, but is a driver annoyance situation. This noise can be significantly reduced by installing a noise reduction disk, Sheppard Part Number **3331991K**, in the return line of the steering gear.

Procedure:

1. Secure the vehicle for servicing.
2. Remove the return line taking care to collect the oil in the drain pan.
3. Remove the return fitting from the steering gear. Note the location of the fitting for reassembly.
4. Install the restrictive disk into the return port of the steering gear using the bladed screwdriver in the slot of the restrictive disk. Turn the disk into the port until it bottoms in the port. Do not over tighten.
5. Install the return line fitting into the steering gear. Locate the fitting to properly align with the return hose. Tighten the fitting and install the return hose.
6. Fill the reservoir with an approved fluid, check and correct the fluid level in the reservoir. Start the engine and check for leaks.
7. Remove the drain pan. Should you have any questions on this procedure, please contact Sheppard Power Steering Field Service at 1-800-274-7437.

## Removal / Replacement

### 1 – GETTING STARTED

Hydraulic oil leak was at steering column input shaft seal. With engine running, it leaked oil. Checked with ForeForums Friends, read a lot, and decided on a plan.

Our steering gear is Sheppard M100 PDP1 with manual relief valves. Rebuilder alternatives included Red Head (WA) and Straight Line Steering (CA). We chose Red

Head. Knowledgeable, experienced, answered our many questions ...



**Read a full detailed write up, by Barry & Cindy, on all the steps needed to remove and replace the steering box.**

## Video of the steps and tools required to remove and install the steering box in a U320

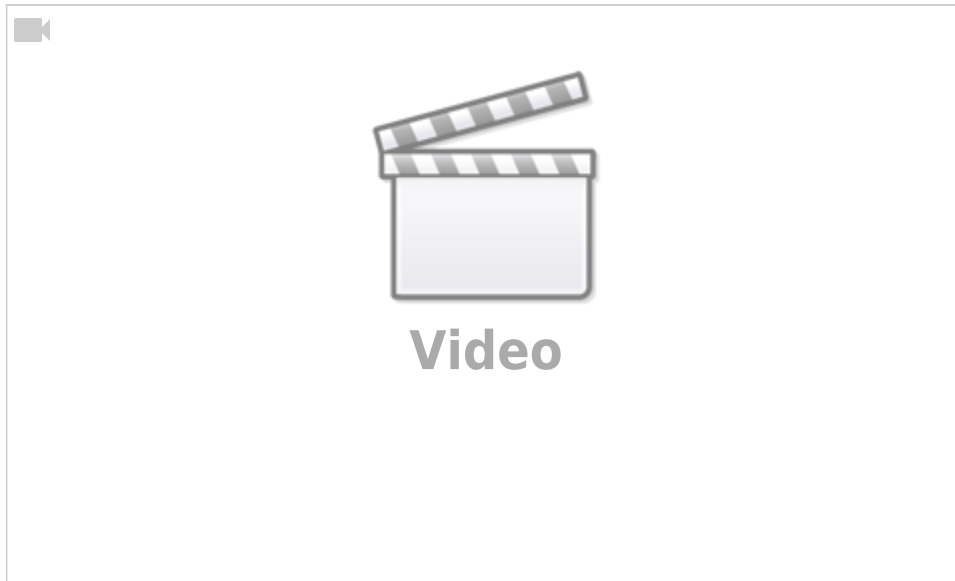

From:

<https://wiki.foreforums.com/> - **Foretravel Wiki**

Permanent link:

<https://wiki.foreforums.com/technical:chassis:sheppard>

Last update: **2024/07/14 18:28**

