

# VARROOM with a view!!

**For 1984: More Muscle, More  
Beauty, More Foretravel!**

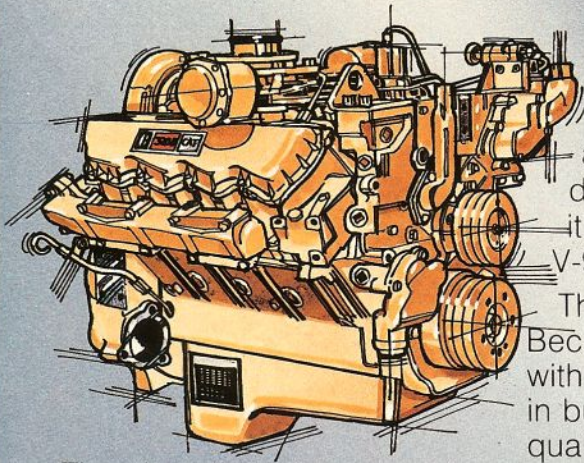

There's nothing tame about this Cat.

It's a more-for-your-money engine that Caterpillar has recently let out of the bag, thanks to some significant developments in fuel delivery, timing, and supercharger technology.

Surprisingly, the Cat purrs along at dramatically lower noise levels than other diesels, yet promises greater improved durability. That's important. Also, the low RPM characteristic provides snappy hill-climbing acceleration at any altitude. But its greatest benefit is fuel savings; it's the best economy mid-range diesel offered anywhere in the world!

Sure, it's a jungle out there, but Foretravel's Cat makes a difference. A powerful difference. Especially when it's mated with the new V-917 Oshkosh chassis.

That's right. Oshkosh. Because it's from a company with 67 years of experience in building rugged, premium quality chassis that set worldwide performance standards.

Because Foretravel wouldn't settle for anything less.



Air-operated wedge brakes with automatic, heated moisture ejector; back-up signal; rear-mounted radiator; two 8-D batteries; 150-gallon fuel tank; heavy duty, balanced and glide-coated propeller shafts; integral hydraulic steering system; air suspension front and rear; Allison MT 643 automatic transmission. A Motor-Aid hot water heater, too.







All of it gliding along on six 12-ply Michelin tires with polished aluminum wheels.

And look at the computerized instrument panel with digital readout controls and integral alarm systems.

Want to check the wiring? The lift-up dash makes it easy.

What more could you ask? Living varoom.

At the Foretravel plant in Nacogdoches, where the Fore family builds comfort into cross-country vehicles, the search never ends for more features, more beauty, more drivability.

More recreation.

You'll luxuriate on a queen-size bed that's the cat's pajamas; sink into a recliner chair to enjoy the rear-view TV. Cable hookup? Absolutely.

The finicky Fores designed your coach with real walnut paneling, cedar-lined closets, all-wood drawers on ball-bearing glides, and a choice

THE V-917 OSHKOSH CHASSIS

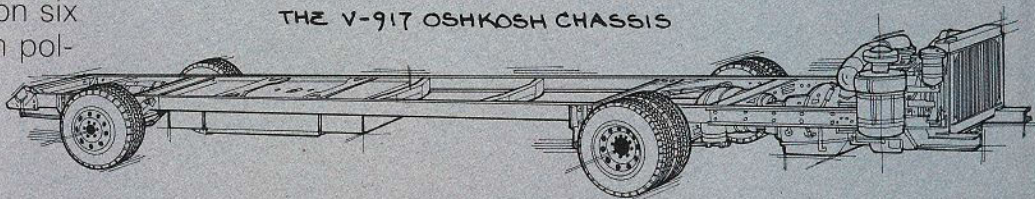

of three exciting new fabrics. Plus all the exciting built-ins like ice-maker, blender and microwave/convection oven.

All these good things, and much more, are protected by tubular steel construction and surrounded by functional aerodynamic styling. So the care and feeding of this Cat (or its littermate 8.2 Detroit Diesel) is modest, while the enjoyment is unlimited. And, when you own a Foretravel, Travco, Avco or GTC, you're

eligible to join the fellowship and fun of the Foretravel Motorcade Club.

It's the purrfect solution.

To get the full story, write or call: Foretravel, Inc., 1221 NW Stallings Drive, Nacogdoches, Texas 75961, (409) 564-8367.



# Foretravel



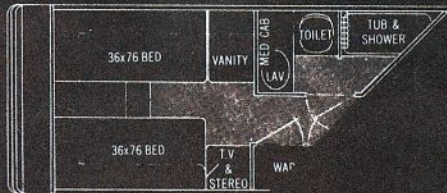
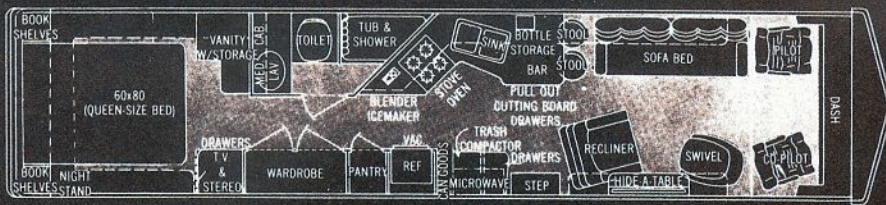

### Foretravel 38' Performance

Fuel consumption\* ..... 9.2 mpg  
 Engine coolant temp.  
 Level ..... 170°F  
 Uphill ..... 185°F  
 Trans oil temp.  
 Level ..... under 140°F  
 Uphill ..... 150°F  
 Acceleration time  
 0-60 mph ..... 37 sec.  
 40-60 mph ..... 18 sec.  
 \*Fuel consumption recorded at 55 mph, 1,800 feet elevation, predominantly flat highway. Ambient temperature 40 degrees F. Uphill test in second gear, 6 percent grade, full throttle.

### Specifications

**Coach**  
 Ext. length ..... 38'3"  
 Ext. width ..... 96"  
 Ext. height ..... 127"  
 Int. height ..... 77"  
 Frame construction ..... Steel reinforced sandwich panel  
 Insulation ..... 1.5" block Styrofoam  
 Water capacity ..... 88 gal.  
 Waste holding capacity ..... 44 gal.  
 Sink/shower holding cap. .... 45 gal.  
 Propane capacity ..... 45.4 gal.  
 Water system type ..... Demand Furnaces ..... 14,500 & 32,000 BTU  
 Refrigerator ..... 10 cu. ft.  
 Toilet ..... Freshwater  
 Electrical ..... 70 amp. convertor-charger  
 Air-conditioner .... Twin 13,500 BTU  
 Generator ..... 6.5 kw

**Chassis** ..... Oshkosh  
 Engine ..... Caterpillar 3208-T  
 Transmission ..... Allison MT 643 automatic 4-speed  
 Axle ratio ..... 4.11 to 1  
 Tire size (bias) ..... 9R/22.5 12 ply  
 Wheelbase ..... 252"  
 Brakes ..... Drum, air assisted  
 Suspension ..... Air-ride  
 Cooling system ..... HD standard  
 Trans oil cooling ..... HD standard  
 Fuel capacity ..... 150 gal.  
 Wet weight  
 (Water, fuel, propane tanks full; no supplies or passengers)  
 Front axle ..... 7,540 lbs.  
 Rear axle ..... 12,940 lbs.  
 Right side ..... 10,120 lbs.  
 Left side ..... 10,360 lbs.  
 Total ..... 20,480 lbs.  
 Base sugg. retail price ..... \$163,500

### Chassis Ratings

Front gawr ..... 9,000 lbs.  
 Rear gawr ..... 17,500 lbs.  
 Gvwr\* ..... 26,500 lbs.  
 \*Owner may add up to 6,020 lbs. in weight of passengers and supplies to motorhome equipped as test coach without violating chassis manufacturer's maximum gvwr.

Gawr: gross axle weight rating.  
 Gvwr: gross vehicle weight rating.